



Soup-To-Nuts Workbook

CCIE ROUTING & SWITCHING

**Narbik Kocharians
CCIE #12410
R&S, Security, SP**

3560-Security

Answers

Router & Switch To Switch connection

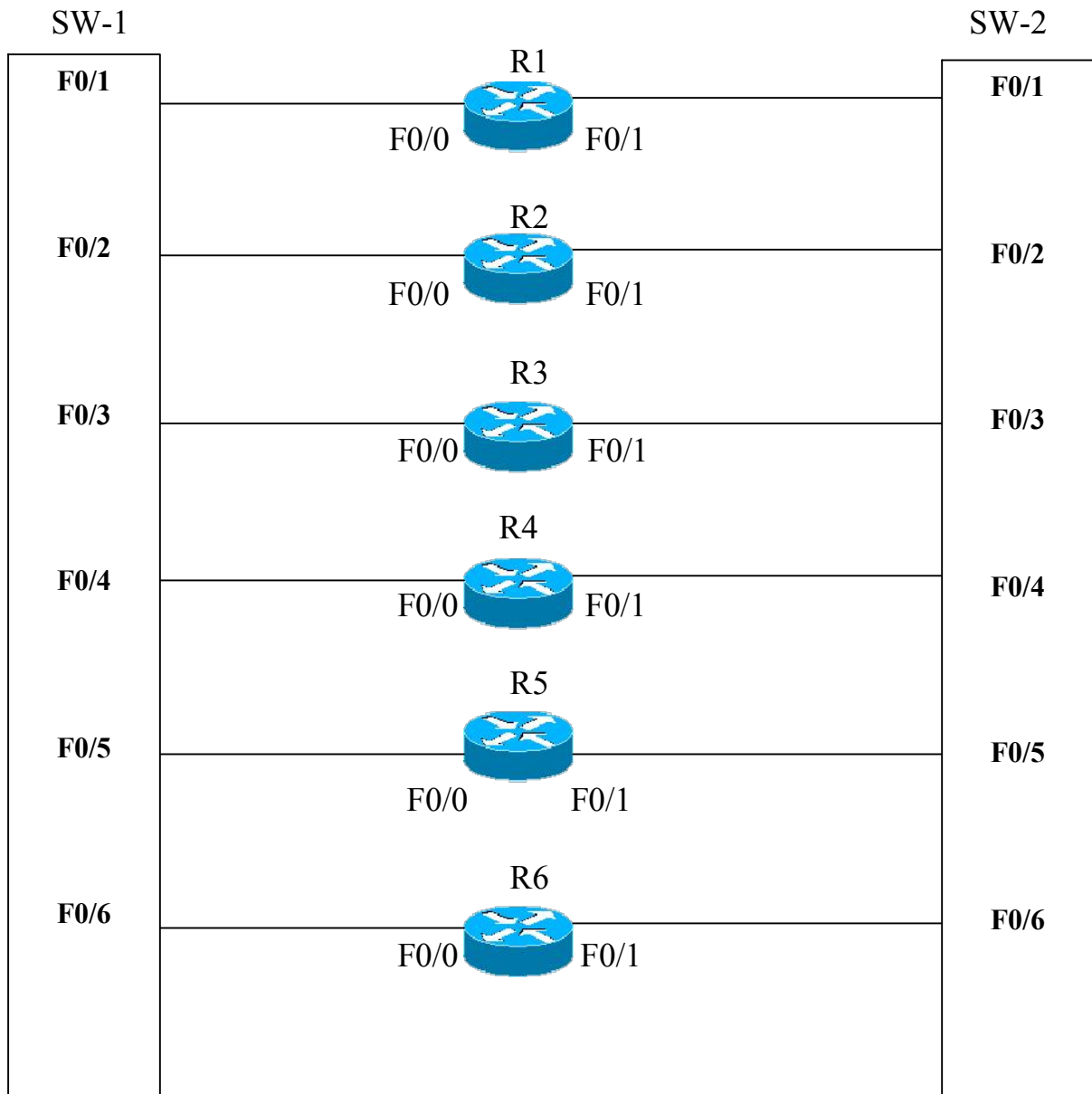

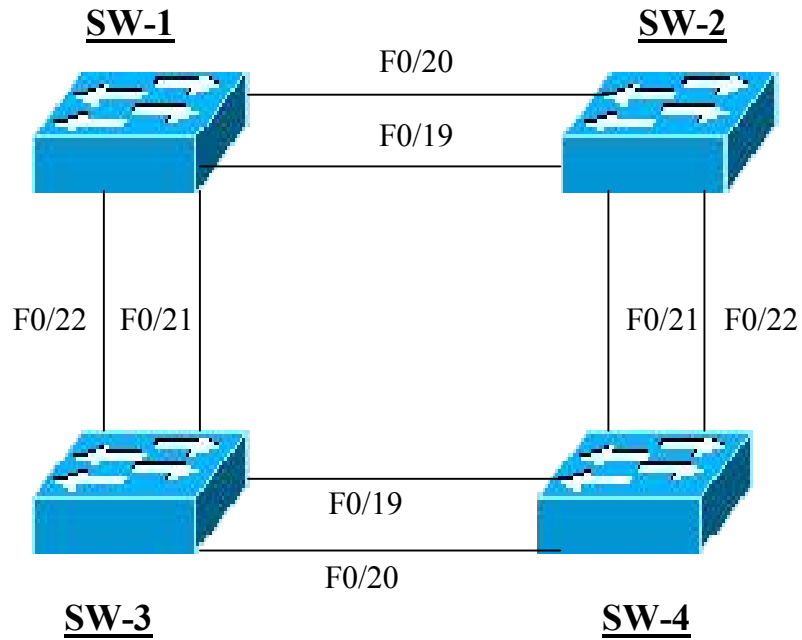

Lab 1

Private VLANs

Task 1

The first switch should be configured with a hostname of SW-1 and the second switch should be configured with a hostname of SW-2

On the First Switch

Hostname SW-1

On the Second Switch

Hostname SW-2

Task 2

Assign IP addressing to the interface of the routers using the following chart and ensure that these routers can ping each other:

Router	Interface	IP address and Subnet mask
R1	F0/0	200.1.1.1 /24
R2	F0/0	200.1.1.2 /24
R3	F0/0	200.1.1.3 /24
R4	F0/1	200.1.1.4 /24
R5	F0/1	200.1.1.5 /24
R6	F0/1	200.1.1.6 /24
BB1	F0/0	200.1.1.10 /24

On R1

Int F0/0
Ip address 200.1.1.1 255.255.255.0
No shut

On R2

Int F0/0
Ip address 200.1.1.2 255.255.255.0
No shut

On R3

Int F0/0
Ip address 200.1.1.3 255.255.255.0
No shut

On R4

Int F0/1
Ip address 200.1.1.4 255.255.255.0
No shut

On R5

Int F0/1
Ip address 200.1.1.5 255.255.255.0
No shut

On R6

Int F0/1
Ip address 200.1.1.6 255.255.255.0
No shut

On BB1

Int F0/0
Ip address 200.1.1.10 255.255.255.0
No shut

To test and verify the configuration:

R1#Ping 200.1.1.2

Type escape sequence to abort.
Sending 5, 100-byte ICMP Echos to 200.1.1.2, timeout is 2 seconds:
!!!!
Success rate is 100 percent (5/5), round-trip min/avg/max = 1/2/4 ms
R1#Ping 200.1.1.3

Type escape sequence to abort.
Sending 5, 100-byte ICMP Echos to 200.1.1.3, timeout is 2 seconds:
!!!!
Success rate is 100 percent (5/5), round-trip min/avg/max = 1/2/4 ms

R1#Ping 200.1.1.4

Type escape sequence to abort.
Sending 5, 100-byte ICMP Echos to 200.1.1.4, timeout is 2 seconds:
!!!!
Success rate is 100 percent (5/5), round-trip min/avg/max = 1/2/4 ms

R1#Ping 200.1.1.5

Type escape sequence to abort.
Sending 5, 100-byte ICMP Echos to 200.1.1.5, timeout is 2 seconds:
!!!!
Success rate is 100 percent (5/5), round-trip min/avg/max = 1/2/4 ms

R1#Ping 200.1.1.6

Type escape sequence to abort.
Sending 5, 100-byte ICMP Echos to 200.1.1.6, timeout is 2 seconds:
!!!!
Success rate is 100 percent (5/5), round-trip min/avg/max = 1/2/4 ms

R1#Ping 200.1.1.10

Type escape sequence to abort.
Sending 5, 100-byte ICMP Echos to 200.1.1.10, timeout is 2 seconds:
!!!!
Success rate is 100 percent (5/5), round-trip min/avg/max = 1/2/4 ms

Task 3

Configure trunking between SW-1 and SW-2 using ports F0/19 and F0/20. Use an industry standard trunking protocol for this purpose.

On Both Switches

Interface range f0/19-20
Switch trunk encap dot1q
Switch mode trunk

To verify the configuration:

On Both Switches

SW-1#Show int trunk

Port	Mode	Encapsulation	Status	Native vlan
Fa0/19	on	802.1q	trunking	1
Fa0/20	on	802.1q	trunking	1

Port	Vlans allowed on trunk
Fa0/19	1-4094
Fa0/20	1-4094

Port	Vlans allowed and active in management domain
Fa0/19	1
Fa0/20	1

Port	Vlans in spanning tree forwarding state and not pruned
Fa0/19	1
Fa0/20	none

SW-2#Show int trunk

Port	Mode	Encapsulation	Status	Native vlan
Fa0/19	on	802.1q	trunking	1
Fa0/20	on	802.1q	trunking	1

Port	Vlans allowed on trunk
Fa0/19	1-4094
Fa0/20	1-4094

Port	Vlans allowed and active in management domain
Fa0/19	1

Fa0/20	1
Port	Vlans in spanning tree forwarding state and not pruned
Fa0/19	1

Task 4

Configure the switches such that the ports that are not used are in administratively down state. Use minimum number of commands for this task.

On SW-1

```
SW-1(config)#Int range F0/4-8,F0/10-18,F0/21-24  
SW-1(config-if)#Shut
```

On SW-2

```
SW-2(config)#Int range F0/1-3,F0/7-F0/18,F0/21-24  
SW-2(config-if)#Shut
```

Task 5

Configure SW-1 and SW-2 to implement the following policy:

- Routers R1, R2 and R5 should be able to ping and have reachability to each other. R2 and R5 should NOT have reachability to any other router in this lab.
- Routers R3, R4 and R1 should be able to ping and have reachability to each other. R3 and R4 should NOT have reachability to any other router in this lab.
- Routers R6 and R1 should be able to ping and have reachability to each other. R6 should NOT have reachability to any other router in this lab.
- Routers BB1 and R1 should be able to ping and have reachability to each other. BB1 should NOT have reachability to any other router in this lab.
- Ensure that R6 and BB1 are in the same VLAN; DO NOT use the “switchport protected”, or ACLs to accomplish any of these tasks. You should only see 4 VLANs created in the output of the “Show vlan brief” command.

On Both Switches:

(config)#vtp mode transparent

(config)#vlan 10
(config-vlan)#private-vlan primary

(config)#vlan 25
(config-vlan)#private-vlan community

(config)#vlan 34
(config-vlan)#private-vlan community

(config)#vlan 61
(config-vlan)#private-vlan isolated

(config)#vlan 10
(config-vlan)#private-vlan association add 25,34,61

To verify the configuration:

Show vlan private-vlan

Primary	Secondary	Type	Ports
10	25	community	
10	34	community	
10	61	isolated	

On SW-1

SW-1(config)#Int F0/1
SW-1(config-if)# Switchport private-vlan mapping 10 25,34,61
SW-1(config-if)# Switchport mode private-vlan promiscuous

SW-1(config-if)#Int F0/2
SW-1(config-if)#Switchport mode private-vlan host
SW-1(config-if)#Switchport private-vlan host-association 10 25

SW-1(config-if)#Int F0/3
SW-1(config-if)#Switchport mode private-vlan host
SW-1(config-if)#switchport private-vlan host-association 10 34

```
SW-1(config)#Int F0/9
SW-1(config-if)#Switchport mode private-vlan host
SW-1(config-if)#Switchport private-vlan host-association 10 61
```

On SW-2

```
SW-2(config)#Int F0/4
SW-2(config-if)# Switchport mode private-vlan host
SW-2(config-if)# Switchport private-vlan host-association 10 34
```

```
SW-2(config)#Int F0/5
SW-2(config-if)#Switchport mode private-vlan host
SW-2(config-if)#Switchport private-vlan host-association 10 25
```

```
SW-2(config)#Int F0/6
SW-2(config-if)#Switchport mode private-vlan host
SW-2(config-if)#switchport private-vlan host-association 10 61
```

To verify the configuration:

On SW-2

```
SW-2#Show vlan private-vlan
```

Primary	Secondary	Type	Ports
-----	-----	-----	-----
10	25	community	Fa0/5
10	34	community	Fa0/4
10	61	isolated	Fa0/6

On SW-1

```
SW-1#Show vlan private-vlan
```

Primary	Secondary	Type	Ports
-----	-----	-----	-----
10	25	community	Fa0/1, Fa0/2
10	34	community	Fa0/1, Fa0/3
10	61	isolated	Fa0/1, Fa0/9

To test the configuration:

On R1

R1#Ping 200.1.1.2

Type escape sequence to abort.

Sending 5, 100-byte ICMP Echos to 200.1.1.2, timeout is 2 seconds:

!!!!

Success rate is 100 percent (5/5), round-trip min/avg/max = 1/1/4 ms

R1#Ping 200.1.1.3

Type escape sequence to abort.

Sending 5, 100-byte ICMP Echos to 200.1.1.3, timeout is 2 seconds:

!!!!

Success rate is 100 percent (5/5), round-trip min/avg/max = 1/2/4 ms

R1#Ping 200.1.1.4

Type escape sequence to abort.

Sending 5, 100-byte ICMP Echos to 200.1.1.4, timeout is 2 seconds:

!!!!

Success rate is 100 percent (5/5), round-trip min/avg/max = 1/2/4 ms

R1#Ping 200.1.1.5

Type escape sequence to abort.

Sending 5, 100-byte ICMP Echos to 200.1.1.5, timeout is 2 seconds:

!!!!

Success rate is 100 percent (5/5), round-trip min/avg/max = 1/2/4 ms

R1#Ping 200.1.1.6

Type escape sequence to abort.

Sending 5, 100-byte ICMP Echos to 200.1.1.6, timeout is 2 seconds:

!!!!

Success rate is 100 percent (5/5), round-trip min/avg/max = 1/2/4 ms

R1#Ping 200.1.1.10

Type escape sequence to abort.

Sending 5, 100-byte ICMP Echos to 200.1.1.10, timeout is 2 seconds:
!!!!
Success rate is 100 percent (5/5), round-trip min/avg/max = 1/2/4 ms

On R2

R2#Ping 200.1.1.1

Type escape sequence to abort.
Sending 5, 100-byte ICMP Echos to 200.1.1.1, timeout is 2 seconds:
!!!!
Success rate is 100 percent (5/5), round-trip min/avg/max = 1/1/4 ms

R2#Ping 200.1.1.3

Type escape sequence to abort.
Sending 5, 100-byte ICMP Echos to 200.1.1.3, timeout is 2 seconds:
.....
Success rate is 0 percent (0/5)

R2#Ping 200.1.1.4

Type escape sequence to abort.
Sending 5, 100-byte ICMP Echos to 200.1.1.4, timeout is 2 seconds:
.....
Success rate is 0 percent (0/5)

R2#Ping 200.1.1.5

Type escape sequence to abort.
Sending 5, 100-byte ICMP Echos to 200.1.1.5, timeout is 2 seconds:
!!!!
Success rate is 100 percent (5/5), round-trip min/avg/max = 1/1/4 ms

R2#Ping 200.1.1.6

Type escape sequence to abort.
Sending 5, 100-byte ICMP Echos to 200.1.1.6, timeout is 2 seconds:
.....
Success rate is 0 percent (0/5)

R2#Ping 200.1.1.10

Type escape sequence to abort.
Sending 5, 100-byte ICMP Echos to 200.1.1.10, timeout is 2 seconds:

.....
Success rate is 0 percent (0/5)

On R3

R3#Ping 200.1.1.1

Type escape sequence to abort.
Sending 5, 100-byte ICMP Echos to 200.1.1.1, timeout is 2 seconds:
!!!!
Success rate is 100 percent (5/5), round-trip min/avg/max = 1/2/4 ms

R3#Ping 200.1.1.2

Type escape sequence to abort.
Sending 5, 100-byte ICMP Echos to 200.1.1.2, timeout is 2 seconds:
.....
Success rate is 0 percent (0/5)

R3#Ping 200.1.1.4

Type escape sequence to abort.
Sending 5, 100-byte ICMP Echos to 200.1.1.4, timeout is 2 seconds:
!!!!
Success rate is 100 percent (5/5), round-trip min/avg/max = 1/1/4 ms

R3#Ping 200.1.1.5

Type escape sequence to abort.
Sending 5, 100-byte ICMP Echos to 200.1.1.5, timeout is 2 seconds:
.....
Success rate is 0 percent (0/5)

R3#Ping 200.1.1.6

Type escape sequence to abort.
Sending 5, 100-byte ICMP Echos to 200.1.1.6, timeout is 2 seconds:
.....
Success rate is 0 percent (0/5)

R3#Ping 200.1.1.10

Type escape sequence to abort.
Sending 5, 100-byte ICMP Echos to 200.1.1.10, timeout is 2 seconds:

.....
Success rate is 0 percent (0/5)

On R4

R4#Ping 200.1.1.1

Type escape sequence to abort.
Sending 5, 100-byte ICMP Echos to 200.1.1.1, timeout is 2 seconds:
!!!!
Success rate is 100 percent (5/5), round-trip min/avg/max = 1/2/4 ms

R4#Ping 200.1.1.2

Type escape sequence to abort.
Sending 5, 100-byte ICMP Echos to 200.1.1.2, timeout is 2 seconds:
.....
Success rate is 0 percent (0/5)

R4#Ping 200.1.1.3

Type escape sequence to abort.
Sending 5, 100-byte ICMP Echos to 200.1.1.3, timeout is 2 seconds:
!!!!
Success rate is 100 percent (5/5), round-trip min/avg/max = 1/1/4 ms

R4#Ping 200.1.1.5

Type escape sequence to abort.
Sending 5, 100-byte ICMP Echos to 200.1.1.5, timeout is 2 seconds:
.....
Success rate is 0 percent (0/5)

R4#Ping 200.1.1.6

Type escape sequence to abort.
Sending 5, 100-byte ICMP Echos to 200.1.1.6, timeout is 2 seconds:
.....
Success rate is 0 percent (0/5)

R4#Ping 200.1.1.10

Type escape sequence to abort.
Sending 5, 100-byte ICMP Echos to 200.1.1.10, timeout is 2 seconds:

.....
Success rate is 0 percent (0/5)

On R5

R5#Ping 200.1.1.1

Type escape sequence to abort.
Sending 5, 100-byte ICMP Echos to 200.1.1.1, timeout is 2 seconds:
!!!!
Success rate is 100 percent (5/5), round-trip min/avg/max = 1/2/4 ms

R5#Ping 200.1.1.2

Type escape sequence to abort.
Sending 5, 100-byte ICMP Echos to 200.1.1.2, timeout is 2 seconds:
!!!!
Success rate is 100 percent (5/5), round-trip min/avg/max = 1/2/4 ms

R5#Ping 200.1.1.3

Type escape sequence to abort.
Sending 5, 100-byte ICMP Echos to 200.1.1.3, timeout is 2 seconds:
.....
Success rate is 0 percent (0/5)

R5#Ping 200.1.1.4

Type escape sequence to abort.
Sending 5, 100-byte ICMP Echos to 200.1.1.4, timeout is 2 seconds:
.....
Success rate is 0 percent (0/5)

R5#Ping 200.1.1.6

Type escape sequence to abort.
Sending 5, 100-byte ICMP Echos to 200.1.1.6, timeout is 2 seconds:
.....
Success rate is 0 percent (0/5)

R5#Ping 200.1.1.10

Type escape sequence to abort.
Sending 5, 100-byte ICMP Echos to 200.1.1.10, timeout is 2 seconds:
.....

Success rate is 0 percent (0/5)

On R6

R6#Ping 200.1.1.1

Type escape sequence to abort.

Sending 5, 100-byte ICMP Echos to 200.1.1.1, timeout is 2 seconds:

!!!!

Success rate is 100 percent (5/5), round-trip min/avg/max = 1/1/4 ms

R6#Ping 200.1.1.2

Type escape sequence to abort.

Sending 5, 100-byte ICMP Echos to 200.1.1.2, timeout is 2 seconds:

.....

Success rate is 0 percent (0/5)

R6#Ping 200.1.1.3

Type escape sequence to abort.

Sending 5, 100-byte ICMP Echos to 200.1.1.3, timeout is 2 seconds:

.....

Success rate is 0 percent (0/5)

R6#Ping 200.1.1.4

Type escape sequence to abort.

Sending 5, 100-byte ICMP Echos to 200.1.1.4, timeout is 2 seconds:

.....

Success rate is 0 percent (0/5)

R6#Ping 200.1.1.5

Type escape sequence to abort.

Sending 5, 100-byte ICMP Echos to 200.1.1.5, timeout is 2 seconds:

.....

Success rate is 0 percent (0/5)

R6#Ping 200.1.1.10

Type escape sequence to abort.

Sending 5, 100-byte ICMP Echos to 200.1.1.10, timeout is 2 seconds:

.....

Success rate is 0 percent (0/5)

On BB1

BB1#Ping 200.1.1.1

Type escape sequence to abort.

Sending 5, 100-byte ICMP Echos to 200.1.1.1, timeout is 2 seconds:

!!!!

Success rate is 100 percent (5/5), round-trip min/avg/max = 1/1/4 ms

BB1#Ping 200.1.1.2

Type escape sequence to abort.

Sending 5, 100-byte ICMP Echos to 200.1.1.2, timeout is 2 seconds:

.....

Success rate is 0 percent (0/5)

BB1#Ping 200.1.1.3

Type escape sequence to abort.

Sending 5, 100-byte ICMP Echos to 200.1.1.3, timeout is 2 seconds:

.....

Success rate is 0 percent (0/5)

BB1#Ping 200.1.1.4

Type escape sequence to abort.

Sending 5, 100-byte ICMP Echos to 200.1.1.4, timeout is 2 seconds:

.....

Success rate is 0 percent (0/5)

BB1#Ping 200.1.1.5

Type escape sequence to abort.

Sending 5, 100-byte ICMP Echos to 200.1.1.5, timeout is 2 seconds:

.....

Success rate is 0 percent (0/5)

BB1#Ping 200.1.1.6

Type escape sequence to abort.

Sending 5, 100-byte ICMP Echos to 200.1.1.6, timeout is 2 seconds:

.....

Success rate is 0 percent (0/5)

Private-VLANs are typically seen in service provider networks, this feature addresses two major problems that the providers used to face:

1. **Number of Clients: If every client was in a VLAN of their own, the provider will be restricted to 4096 clients, which is the maximum number of VLANs on a given switch.**
2. **Routing between VLANs & IP addressing: Routing between VLANs will be a nightmare, and the number of wasted IP addresses that result from Subnetting will be enormous.**

Using Private-VLANs solves these two issues, with Private-VLANs a VLAN is subdivided into sub-VLANs or sub-domains.

Private-VLANs consist of one primary, and many secondary VLANs, the secondary VLANs can be either Community VLANs or Isolated VLANs.

A Primary VLAN can have many Community VLANs, but it can ONLY have a single Isolated VLAN.

Ports in a Private-VLAN:

There are three types of ports in Private-VLAN and they are as follows:

1. **Promiscuous: A promiscuous port belongs to the primary VLAN; this port can communicate with all ports that are member of a secondary VLAN (Community and/or Isolated) that are associated with the primary VLAN that it belongs.**
2. **Isolated: An isolated port is a host port that belongs to an isolated secondary VLAN. The host ports that are member of a given Isolated VLAN can NOT communicate with each other. These ports can ONLY communicate with the promiscuous port/s.**
3. **Community: A community port is a host port that belongs to a community secondary VLAN. Community ports can communicate with ports in the same community VLAN and with the promiscuous ports. These ports can NOT communicate with other ports in other Community VLANs.**

Task 6

Erase the startup config and reload the routers before proceeding to the next task.